

**MODEL 9000
THERMOMETER**

OPERATOR'S MANUAL

DESIGN CONCEPTS, INC.

707 N. Lindenwood

Olathe, Kansas 66062

PHONE : (913) 782-5672

FAX : (913) 782-5766

E-MAIL : sales@designconceptsinc.biz

TABLE OF CONTENTS

Specifications	3
Options	4
Description	5
Switch Functions.....	5
LED Indicators	6
Setup	7
Startup Message.....	7
Thermocouple Type Setup	7
Legend Selection	7
Display Mode	7
Set Peak Reading Mode	8
Analog Output Setup.....	8
Analog Output Span.....	8
Limit Setup	9
Guard band	10
Baud Rate Setup	10
Serial Address Selection	10
Echo and Line Feed Selection	10
Continuous Update Time	11
Serial Legend Setup	11
Serial Device Code Setup.....	11
Serial Communications.	12
Calibration	16
Check Calibration	17
Connections.....	18
Dimensions	20
Warranty	21

SPECIFICATIONS:

Power Requirements:

- AC: 105VAC to 132VAC @ 50mA (47Hz to 63Hz)
- AC: 198VAC to 264VAC @ 25mA (47Hz to 63Hz) optional

Ranges and Accuracy:

• Type J	-200 to 760°C	-200 to 0 ± 0.5°C	0 to 760°C ± 0.1°C
	-328 to 1400°F	-328 to 32 ± 0.5°F	32 to 1400 ± 0.1°F
• Type K	-270 to 1370°C	± 0.9°C	
	-454 to 2498°F	± 1.6°F	
• Type T	-200 to 400°C	± 0.8°C	
	-454 to 752°F	± 1.4°F	
• Type E	-200 to 650°C	± 1.0°C	
	-148 to 1202°F	± 2.0°F	
• Type R	0 to 1000°C	± 6.0°C	
	32 to 1832°F	± 12°F	
• Type S	0 to 1000°C	± 1.5°C	
	32 to 1832°F	± 3.0°F	

Display:

- Type Five digit, seven segment LED 0.56" (14.3mm) high °F or °C indicator
- Polarity Indication: "-" Displayed
- Overrange Indication: Thermocouple display shows "OPEN"

Limit Outputs:

- Two form "A" relay closures rated .5A at 28VDC (Resistive).

Environmental:

- Operating Temperature Range: -20°C to +60°C
- Storage Temperature Range: -25°C to +85°C
- Relative Humidity: 0% to 90%, Non-condensing.

Dimensions:

- Case size "D" Refer to page XX.
- Weight: 1 pound.
- I/O Terminations: Fifteen quick disconnect terminals.

Analog to Digital Conversions:

- Technique: 16 Bit Sigma Delta
- Rate: 3 Conversions/Second

Analog Output (optional):

- Voltage: 0-10V, 2.5mV resolution, 0V and 10V points are programmable via front panel switches.
Maximum drive capability $\pm 2\text{mA}$.
- CMV: 1400V Peak (AC or DC) Between analog output, digital ground and AC power line to earth ground.
- 4-20mA output, maximum load 600 Ω . The 4mA and the 20mA points are programmable via front panel switches.

Serial Interface (optional):

- ASCII RS-232 or RS-485 compatible (optional); format 1 start bit, 8 data bits, 1 stop bit, and no parity bits. Baud Rates: 9600, 4800, 2400, 1200, 600, 300, 150, & 75 programmable from the front panel. Output compatible with DCI Model 9100 Remote Readout.

Thermocouple Inputs:

- Thermocouple Types: J, K, T, E, R, and S.
- Input Impedance: over 10M Ω
- External (Lead) Resistance Effect: up to 500 Ω lead resistance for rated accuracy.
- Cold Junction Compensation Error: $\pm 0.5^\circ\text{C}$ Max
- Open Thermocouple: "OPEN"
- Thermocouple Short to AC line: Internal Protection Provided to 300V Peak, (200V AC RMS)
- Temperature Resolution: 1 $^\circ\text{C}/1^\circ\text{F}$
- Temperature Coefficient: $\pm 25\text{ppm}/^\circ\text{C}$ typ; $\pm 60\text{ppm}/^\circ\text{C}$ max

OPTIONS:

- 01 RS-232 Compatible Interface
- 02 RS-485 Compatible Interface
- 05 +5VDC input power 500mA max
- 08 4-20mA output max load 600 Ω
- 09 Analog output, tracks input 0-5VDC or 0-10VDC (programmable)
- 12 9-18VDC power 400mA max
- 22 230VAC; 47Hz to 63Hz input power
- 24 18-36VDC Power 300mA max
- 50 Sunlight Readable Red LED

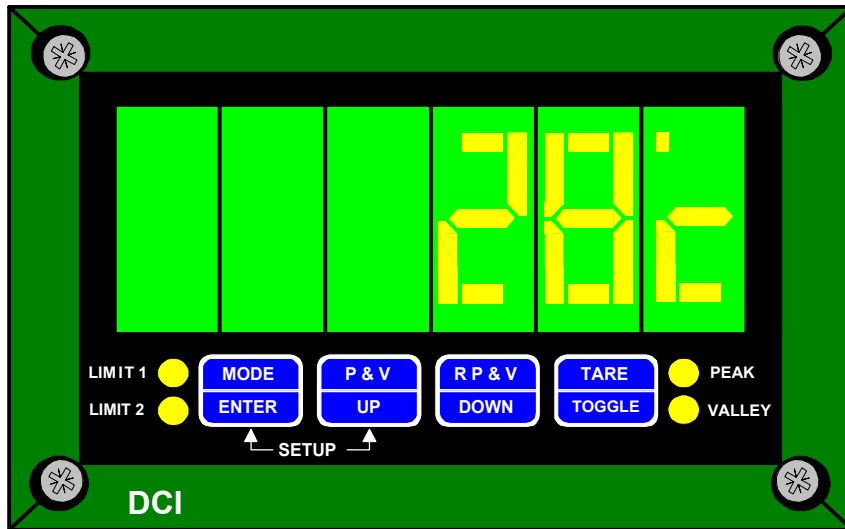

DESCRIPTION:

The model 9000 Thermometer is a microprocessor based high resolution instrument. The 9000 utilizes a 16-bit sigma-delta analog to digital converter. It performs a display update at 2.5 times per second. When the optional analog output is used it also updates 2.5 times per second with either a 0 to 10 volt, or 4-20mA output. When the optional analog output is installed it can be made to open thermocouple condition is brought to the attention of the user by "OPEN" being shown on the display.

SWITCH FUNCTIONS:

On the front the 9000 will be four switches that are placed behind the front lens. Each switch is labeled from left to right as Mode[Enter], P&V[Up], RP&V[Down], and Tare[Toggle]. A description of each switch function is as follows.

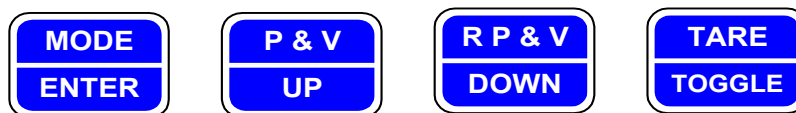



Data Acquisition & Display
Press to set the display mode.

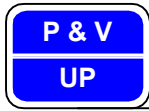

Setup & Calibration Modes
Press to record a complete setting and advance to the next setup.

Data Acquisition & Display
Press to set the display mode for peak, valley, and back to the original mode.



Setup & Calibration Modes
Press to increment the digit/parameter being set.

Data Acquisition & Display
Press to reset the peak or valley.



Setup & Calibration Modes
Press to decrement the digit/parameter being set.

Data Acquisition & Display

Setup & Calibration Modes
Press to advance to the next digit to be set/toggle channels.

LED INDICATORS:



Programmable to illuminate or extinguish when the display reading meets or exceeds the set limit.



Programmable to illuminate or extinguish when the display reading meets or exceeds the set limit.



Illuminates when the display is set to peak mode.



Illuminates when the display is set to valley mode.

SETUP:

The meter setup is accomplished by using the four front panel switches. The setup mode is entered by pressing the Mode[Enter] and P&V[Up] switches simultaneously. The setup procedures are as follows.

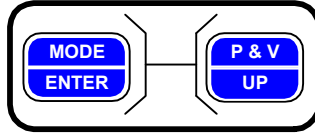

Note: If not pressed simultaneously the unit may go into peak/valley mode upon exiting the setup mode. The peak/valley LED will be illuminated and the peak/valley reading will be displayed.

Startup Message:

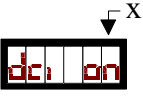
Upon entering the setup mode the display shows  where "x" is either "on" or "off". By pressing Tare[Toggle] you can toggle back and forth from on and off. When set to off the unit will not display the "dciinc", "9000", and the version number on power up. Press Mode[Enter] switch to proceed to the next setup function..

Thermocouple Type Setup:

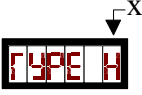
Display will flash  then display will show  where "x" is the thermocouple type. Press Tare[Toggle] will cycle through the available thermocouple types. The available thermocouple types are J, K, T, E, R, and S. Press Mode[Enter] switch to proceed to the next setup function.

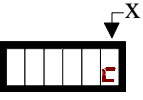

Legend Selection:

Display will flash  then display will show  where "x" is the legend. The legend can be either "F" for Fahrenheit or "c" for Celsius. Pressing Tare[Toggle] will toggle the display from "F" to "c". Press Mode[Enter] switch to proceed to the next setup function.

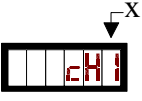
Display Mode:



Display will flash  then the display will show  where "x" is the desired display mode upon exiting the setup. The possible display modes are "cH1", "cH2", "PLUS", "MinUS", "MULT", and "div". Pressing Tare[Toggle] will toggle the display through the possible displays modes. ". Press Mode[Enter] switch to proceed to the next setup function.

Set Peak Reading Mode:

Display will flash  then the display will show  where "x" is either "norm", "d peak", "s peak", or "ds peak". The "d" stands for display and the "s" stands for serial. This function determines how the peak reading is used. It can be put on the display, send over the serial, or sent to both. Pressing Tare[Toggle] will advance through each of these options. Note that this mode can also be achieved for the display by pressing P&V[Up] when the unit is in normal operating mode. Press Mode[Enter] switch to proceed to the next setup function.





Set Valley Reading Mode:

Display will flash  then the display will show  where "x" is either "norm", "d val", "s val", or "ds val". The "d" stands for display and the "s" stands for serial. This function determines how the valley reading is used. It can be put on the display, sent over the serial, or sent to both. Pressing Tare[Toggle] will advance through each of these options. Note that this mode can also be achieved for the display by pressing P&V[Up] twice in the units normal operating mode. Press Mode[Enter] switch to proceed to the next setup function.





Analog Output Setup:

If the analog output option has been installed the display will flash  then the display will show  where "x" is the analog output zero value. If not go to limit setup. This value is what the display reads when the analog output is 0 volts or 4mA. This value can be any number up to $\pm 30,000$ counts not to exceed set analog output span value. To change this value, follow this procedure, P&V[Up] increments the selected digit and RP&V[Down] decrements the selected digit. The Tare[Toggle] switch selects the desired digit to be incremented or decremented. Upon entering any setup function the LSD (far right displayed digit is selected. At each press of the Tare[Toggle] switch moves the selected digit to the left and back to LSD. Press the Mode[Enter] switch to proceed to the next setup function.



Set Analog Output Span:

Display will flash  then the display will show  where "x" is analog output span value. This value is what the display reads when the analog output is at 10 volts or 20mA. This value can be any number from $\pm 1,000$ to $\pm 30,000$ not to fall below set analog output zero value. To change this value, follow this procedure, P&V[Up] increments the selected digit and RP&V[Down] decrements the selected digit. The Tare[Toggle] switch selects the desired digit to be incremented or decremented. Upon entering any setup function the LSD (far right displayed digit is selected. At each press of the Tare[Toggle] switch moves the selected digit to the left and back to LSD. Press the Mode[Enter] switch to proceed to the next setup function.



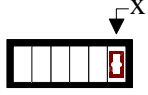

Limit 1 Setup:

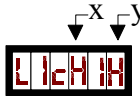
Display will flash  then the display will show  where "x" is limit 1 value. This value can be any number up to $\pm 30,000$ counts. To change this value, follow this procedure, P&V[Up] increments the selected digit and RP&V[Down] decrements the selected digit. The Tare[Toggle] switch selects the desired digit to be incremented or decremented. Upon entering any setup function the LSD (far right displayed digit is selected. At each press of the Tare[Toggle] switch moves the selected digit to the left and back to LSD. Press the Mode[Enter] switch to proceed to the next setup function.

Display will show  where "x" is function that limit 1 will monitor. For example, if desired, to have limit 1 operate on CH2 set "x" to CH2, this is done by pressing P&V[Up] switch. When "y" is "H" the limit activates above the display reading or "L" activates the limit below the display reading. To change "y" press the RP&V[Down] switch. Press the Mode[Enter] switch to proceed to the next setup function.

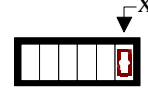
Limit 2 Setup:

Display will flash  then the display will show  where "x" is limit 1 value. This value can be any number up to $\pm 30,000$ counts. To change this value, follow this procedure, P&V[Up] increments the selected digit and RP&V[Down] decrements the selected digit. The Tare[Toggle] switch selects the desired digit to be incremented or decremented. Upon entering any setup function the LSD (far right displayed digit is selected. At each press of the Tare[Toggle] switch moves the selected digit to the left and back to LSD. Press the Mode[Enter] switch to proceed to the next setup function.

Display will show  where "x" is function that limit 1 will monitor. For example, if desired, to have limit 1 operate on CH2 set "x" to CH2, this is done by pressing P&V[Up] switch. When "y" is "H" the limit activates above the display reading or "L" activates the limit below the display reading. To change "y" press the RP&V[Down] switch. Press the Mode[Enter] switch to proceed to the next setup function.

Guardband Setup:

Display will show  where "x" is the guardband value. This function will allow control over the limit setting for control applications. The three digit number is the guardband setting in counts. The guardband setting will allow the reading to fall within a window before limit activation occurs. For example: if the limit were set at 500, the guardband set at 5, and the limit activates as a high limit. If the reading were 490 the limit would be off, if the reading were 500 the limit would be on, if the limit were on and the readings starts to fall the limit would not turn off until the reading falls below 495. This feature is useful when using a heater to control the temperature of a liquid. To change the guardband setting, pressing P&V[Up] will increment the number by one, and pressing RP&V[Down] will decrement the number by one. Press Mode[Enter] to complete set up, unit will flash "done" then exit normal operation. If option 01 or 02 is installed pressing Mode[Enter] will continuous to serial communications set up.

Note: See the serial communications section on page 12 for more information on the following setups. Note that the baud rate setup, unit address setup, echo, line feed, continuous update, and the serial command setups apply only if you have options 01 or 02 installed on the instrument.

Baud Rate Selection:

Display will show  where "x" is desired baud rate, use the P&V[Up] or RP&V[Down] to toggle through the available settings (9600, 4800, 2400, 1200, 600, 300, 150, and 75). Press the Mode[Enter] switch to proceed to the next setup function.

Unit Address Setup:

Display will show  where "x" is desired address, use the P&V[Up] or RP&V[Down] to program the unit's address. The address used must be in the range of 0 to 255. Press the Mode[Enter] switch to proceed to the next setup function.

Echo and Line Feed Setup:

Display will show  where "x" is the desired echo command, the echo command is used to turn the auto echo function on or off. When on the unit automatically retransmits all received serial data. When the selected value "x" is a 1 the echo function is turned on, conversely when "x" is 0 the echo function is turned off. Where "y" is the desired line feed command, the lined feed command is used to turn the line feed function on or off. When the line feed is on the unit will add a line feed character (1) to every message. When the selected value "y" is a 1 the line feed character is transmitted, conversely when "y" is 0 the lined feed character is not transmitted. To turn the line feed function on/off use the RP&V[Down] switch. Press the Mode[Enter] switch to proceed to the next setup function.

Continuous Update Time:

Display will show  where "x" is the desired update time. The continuous reading command allows an auto serial update mode to be selected. A value of -1 will output data once for every conversion (10 times per second). A value of one or greater will indicate the number of seconds between updates, up to the maximum of 3600 seconds between updates. The value of zero will disable the auto update function. To program the continuous update setting (-1 to 3600) using the P&V[Up], RP&V[Down] switches to move in either direction. Press the Mode[Enter] switch to proceed to the next setup function.

Legend Setup:

Display will show  where "x" is the desired legend. The legend setup command allows the selection of a unit to define the transmitted reading, refer to Legend Table. Use the P&V[Up], RP&V[Down] switches to select a legend number from the legend table below. Press the Mode[Enter] switch to proceed to the next setup function.

Legend Table

1. – LBS	6. – F.	11. – KOhms	16. – RPM	21. – Hz
2. – TEMP	7. – Mv	12. – Mohms	17. – FPM	22. – VAC
3. – C	8. – V	13. – PSI	18. – GPM	23. – mRADS
4. – C.	9. – A	14. – PSIA	19. – MPH	
5. – F	10. – Ohms	15. – PSIG	20. – IPM	

Serial Command Setup:

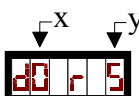
Display will show  where "x" is device code, a 1 will enable and 0 will disable. Where "y" is the command to send to the next unit in the string. Remote serial command is most widely used if several units are connected together in series to the same printer. A device code allows the units to "take turns" on a serial bus. When two or more units are connected serially and set for the same bus, the first unit in the string can have its device in the string. When serial command is sent a value (XYY) the first attached number (YY) is the corresponding number for the remote serial command. A table of these numbers can be found in the serial communication section on Page 12. Use the P&V[Up] switch to select the device code, RP&V[Down] will change "r". Press the Mode[Enter] switch to proceed to the next setup function.

SERIAL COMMUNICATIONS:

If the serial input/output option is installed it allows the Series 9000 to communicate with a remote computer, terminal, or printer. Two standard serial options levels are available, RS-232 or RS-485. Almost all functions available from the front panel switches can be duplicated by the host computer. Listed below are all commands with their associated remote serial command number. Later in this section a full description is given for each command.

1	EH	Set Echo Mode
2	LF	Set Line Feed Mode
3	AE	Address Enable
4	AD	Address Disable
5	RD	Read Display
6	RP	Read Peak
7	RV	Read Valley
8	S1	Set Limit 1
9	S2	Set Limit 2
10	V1	Read Limit 1
11	V2	Read Limit 2
12	SP	Set Peak
13	SV	Set Valley
14	SZ	Set Display Zero
15	SS	Set Display Span
16	AZ	Set Analog Output Zero
17	AS	Set Analog Output Span
18	DM	Set Display Mode
19	TM	Test Message
20		NOT USED
21		NOT USED
22	CR	Set Continuous Reading Mode and Display Mode
23		NOT USED
24		NOT USED
25		NOT USED
26	LR	Set Legend
27	SC	Set Device Code and Remote Serial Command
28	DP	Set DP Placing
35	PV	Set Peak and Valley Mode

The serial data is transmitted as ASCII characters, using the selected baud rate, each word or character is made up of eight data bits, one stop bit and no parity bit. The format of data transmitted depends on the command, and is expected to be transmitted or received left most character first and terminated with a carriage return (c.r.) when an additional number is required leading zeros or place holders may be omitted. Plus sign is optional but must proceed the number. Received numbers will have the decimal point

ignored. Transmitted numbers will have a period to conform to the display format. In the command descriptions below the command string will be shown within brackets {[]}, the sign if required will be shown as a lower case (s), and the number as upper case (X). Each command will be executed when received and only once except for display data which may be enabled to continuously update until disabled. Most all commands that set some parameter can be sent to the unit without that parameter and it will respond with the current value of that parameter. This allows the user to check those values to be sure the unit received the parameter properly.

Echo: [EHXc.r.]

The echo command is used to turn the echo on and off. When the echo is on the unit will send back out anything that comes in. A zero in place of the X turns the echo off and a one turns the echo on.

Line Feed: [LFXc.r.]

The line feed command is used to turn the line feed on and off. When the line feed is on the unit will follow every message with a line feed character. A zero in place of the X turns the line feed off and a one turns the line feed on.

Address Enable [AEXXXc.r.]

Address enable is a command used with the RS-485 serial interface when several units will be in parallel on the serial buss, or with RS-232 when several units are connected in series, to enable the unit. This command allows the unit specified by the address number XXX to be turned on or enabled, the address must be in the range of 0 to 255. When the address is set to 0 the unit will respond to any command without first receiving the address enable command. When enabled the unit will respond with [HELLOc.r.].

Address Disable [ADXXc.r.],[ADc.r.]

Address disable is a command used with the RS-485 serial interface when several units will be in parallel on the serial buss, or with RS-232 when several units are connected in series, to disable the unit. This command allows the unit specified by the address number XX to be turned off or disabled. The address must be in the range of 1 to 255. If no number is supplied all units on the serial buss will be turned off or disabled. If the unit is disabled by unit address number the unit will respond with [BYEc.r.].

Read Display: [RDc.r.]

Read display is a command that will return the normal display reading, (display mode when not in Peak, Valley, Span check, etc.). The returned data format will be [sXXX.XXXc.r.] where (s) is the sign if minus, (X) is the number, and (.) is the decimal point if in the display.

Read Peak: [RPc.r.]

Read peak is a command that will return the peak display reading. The returned data format will be [sXXX.XXXc.r.] where (s) is the sign if minus, (x) is the number, and (.) is the decimal point if in the display.

Read Valley: [RVc.r.]

Read valley is a command that will return the valley display reading. The returned data format will be [sXXX.XXXc.r.] where (s) is the sign if minus, (X) is the number, and (.) is the decimal point if in the display.

Set Limit: [S#XXXXXXc.r.]

The set limit command is used to program a limit number for the high or low limit. The first number following the command (#) specifies whether the high limit or low limit is being programmed. A one in this field specifies the high limit, while a two specifies the low limit. The number following this (XXXXXX) is the actual limit number to be entered.

Verify Limit: [VXc.r.]

The verify limit command is used to read the current high and low limit settings for the unit. The applied number (X) specifies whether the high or low limit value is to be returned. A one specifies the high limit, while a two specifies the low limit.

Set Peak: [SPc.r.]

Set peak is a command that will set the current peak value to the current actual display reading or reset the peak to the current lowest reading. The unit will respond with [OKc.r.].

Set Valley: [SVc.r.]

Set valley is a command that will set the current valley value to the current actual display reading or reset the valley to current highest reading. The unit will respond with [OKc.r.].

Set Analog Output Zero: [AZXXXXXXc.r.]

Set analog output zero is a command that will set the analog output zero. This number is what the display reads when the analog output is at zero volts or 4mA. "AZ" is the command. "X" is the numeric value from 1 to 999999. X may be preceded by a "+" or a "-". The "+" is optional. The unit will respond with [OKc.r.]

Set Analog Output Span: [ASXXXXXXc.r.]

Set analog output span is a command that will set the analog output span. This number is what the display reads when the analog output is at its full scale point, this can be 10 volts, 5 volts, or 20mA. "AS" is the command. "X" is the numeric value from 1 to 999999. X may be preceded by a "+" or a "-". The "+" is optional. The unit will respond with [OKc.r.].

Set Display Mode: [DMXc.r.]

Set display mode is a command that will set which reading the unit is to display. "X" is the display mode number. This number is 1 for ch1, 2 for ch2 3 for ch1+ch2, 4 for ch1-ch2, 5 for ch1*ch2, and 6 for ch1/ch2. The unit will respond with [OKc.r.].

Test Message: [TMc.r.]

The test message command is a diagnostic aid. When the test message command is received the unit will output all current settings, readings and the model number with software revision.

Continuous Reading: [CFXXXXc.r.]

The continuous reading command allows the auto serial update mode to be selected. It updates all the units with corresponding display data at the selected time interval. The attached number (XXXX) is the numeric value from -1 to 3600. A value of 0 will disable the auto update function. A value of -1 will output data once for every conversion (2.5 times per second). A value of one or greater indicates the number of seconds between updates up to maximum of 3600 seconds between updates.

Set Legend: [LRXXc.r.]

The set legend command allows the selection of a unit indicator, which will be added onto the reading update from the serial output. The number (X) applied to the command indicated which unit from the legend table (on page XX) will be appended to the serial reading.

Set Device Code and Remote Serial Command: [SCX YYc.r.]

This command allows setting the device code and the numerical value for the remote serial command. A full explanation of this feature can be found in the setup mode instructions. "SC" is the command. "X" is a 0 disable the device code or a 1 enable the device code. "YY" is the corresponding number for the remote serial command. A table of these numbers can be found at the top of this section where the serial commands are listed. The unit will respond with [OKc.r.].

Set Peak and Valley Mode: [PVc.r.]

This command allows changing the peak and valley display modes. "PV" is the command. "X" is a numerical value corresponding to the display mode. A value of 0 causes the display and serial to operate normally. A value of 1 will cause the peak value to be sent to the display only. A value of 2 will cause the peak value to be sent only out the serial port only. A value of 3 will cause the peak value to be sent to the display and out the serial port. A value of 4 will cause the valley reading to be sent to the display only. A value of 5 will cause the valley reading to be sent to the display and out through the serial port.

CALIBRATION:

The calibration mode is entered by pressing RP&V[Down] and Tare[Toggle] switches simultaneously.

ⓘ Note: This is the only method to check or change the calibration of this unit externally.

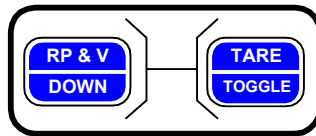

ⓘ Note: Do not enter the calibration mode unless you have appropriate signal source for zero and span calibration.

After enter the calibration mode the unit will flash the introduction to the calibration of the A/D Converter.

eALAdc

52 0

53 FS

Zero Point and Span Point Calibration Programming:

Display will show **52 0 53** this is to show that a zero point and span point is ready to be set. Set the calibrator for 0mV to calibrated the zero point, allow sufficient time, 5 to 10 seconds, for the unit to stabilize. Press the P&V[Up] switch, this will display " 0" and store the zero point. Next set the calibrator for a 40mV to calibrated the span point, allow sufficient time, 5 to 10 seconds, for the unit to stabilize. Then press the RP&V[Down] switch to store span point, this will display " FS" . Press the Mode[Enter] switch to end calibration.

Check Calibration:

In order to check calibration the cold junction reference must be removed from the display reading. To do this press Tare[Toggle] when in calibration, the display will show "crJ off". Subsequent presses of Tare[Toggle] will turn the cold junction reference on and off. With the cold junction off and a type K thermocouple selected, the unit will read 0°C with 0mV input and 967°C with 40mV input. The inputs for calibration in on TB1 terminal block on the rear panel of the instrument. Pin # 10 is the "+" Thermocouple input +, and pin # 11 is the "-" Thermocouple input. Once the calibration readings are confirmed press Tare [Toggle] to turn the cold junction on "crJ on". With the cold junction on, press [Enter] to exit the calibration mode.

9000 CONNECTIONS Back View

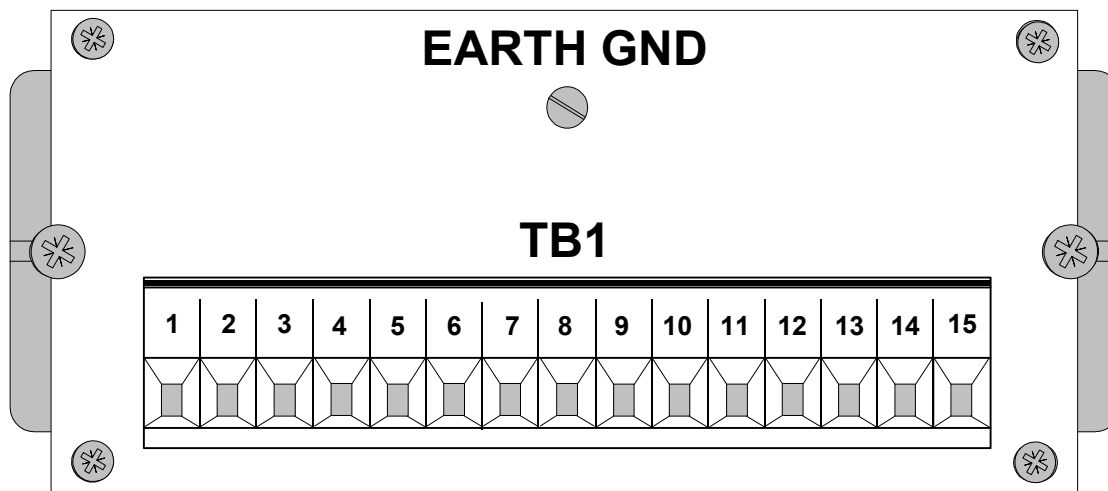

PIN Description

1. +115VAC/-DC Power
2. -115VAC/+DC Power
3. RS-232 Transmit/RS-485
4. RS-232 Receiver/RS-485
5. Digital Ground
6. Limit 1 Normally-Open
7. Limit 1 Common
8. Limit 2 Normally-Open

PIN Description

9. Limit 2 Common
10. Channel 1 Thermocouple Input +
11. Channel 1 Thermocouple Input -
12. Channel 2 Thermocouple Input+
13. Channel 2 Thermocouple Input -
14. Analog Output
15. Analog Ground

Note 1: For proper AC line filtering and safety precautions Pin 1 must be connected to Line, Pin 2 connected to neutral and unit must be to earth ground.

Note 2: Standard Input Power is 115VAC (Optional power is listed below).

- Option 05, Input Power is +5VDC Pin 1 (-) and Pin 2 (+)
- Option 12, Input Power is +9-18VDC Pin 1 (-) and Pin 2 (+)
- Option 22, Input Power is 230VAC
- Option 24, Input Power is +18-36VDC Pin 1 (-) and Pin 2(+)

Thermocouple wire color and polarity:

Type J	White +	Red -
Type T	Blue +	Red -
Type R	Black +	Red -
Type K	Yellow +	Red -
Type E	Purple +	Red -
Type S	Black +	Red -

DIMENSIONS

CASE SIZE D

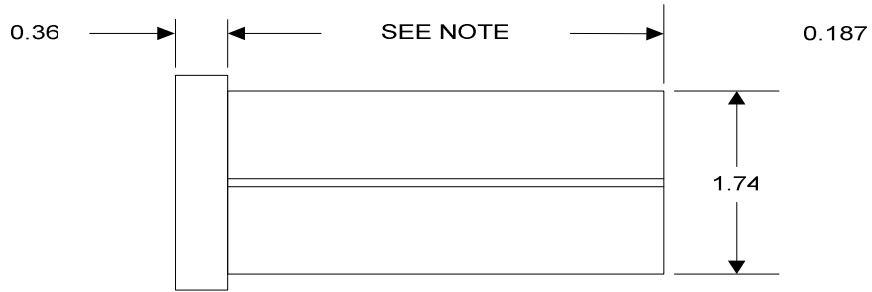

CASE DEPTH SERIES
SERIES 9000: 4.0'

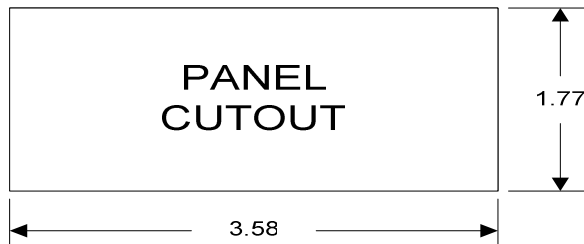

ALL DIMENSIONS IN INCHES
PLEASE ADD .5 INCHES TO DEPTH FOR REAR CONNECTORS

MOUNTING

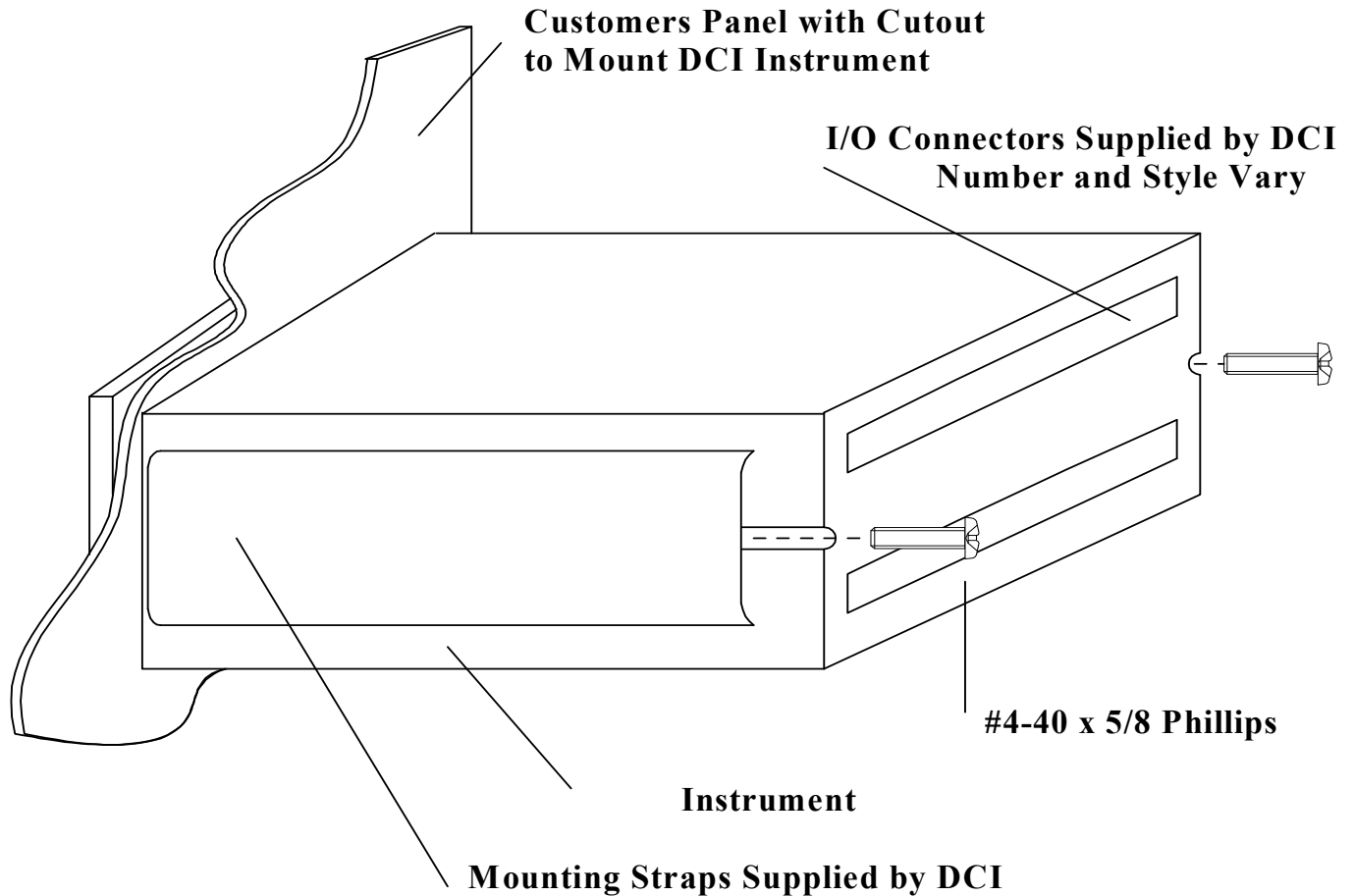

Note: Ground Case per FIGURE 1.0, page 16

Design Concepts, Inc.
P. O. Box 2877
707 N Lindenwood Dr.
Olathe, KS 66062
Phone: 913-782-5672
Fax: 913-782-5766
e-mail info@designconceptsinc.biz

WARRANTY

THE FOLLOWING WARRANTY IS IN LIEU OF ALL OTHER WARRANTIES, EXPRESSED, IMPLIED OR STATUTORY, INCLUDING BUT NOT LIMITED TO ANY IMPLIED WARRANTY OF MERCHANTABILITY OR FITNESS FOR A PARTICULAR PURPOSE.

All new products sold by Design Concepts Inc. are warranted against defects in materials and workmanship for one (1) year from the date of the original shipment. During the warranty period, Design Concepts Inc. will repair or, at its option, replace without charge any Design Concepts Inc. product stated above, is limited to the repaired portion and is valid for ninety (90) days from the date of its reshipment. These warranties do not apply if the product has been damaged by accident, misuse, or modification in the absence of authorization from Design Concepts Inc. Design Concepts Inc. will not be responsible or liable for contingent, incidental, secondary or consequential costs of damages.