

**MODEL 715AN
QUADRATURE
DEGREES COUNTER**

DESIGN CONCEPTS INC

**707 N. Lindenwood
Olathe, Kansas 66062**

PHONE: (913) 782-5672

FAX: (913) 782-5766

E-MAIL : info@dcimeters.com

TABLE OF CONTENTS

2.....	Features
3.....	Specifications
4.....	Setup
6.....	Serial Commands
8.....	Pin Out and switch settings
10.....	Case size
11.....	Mounting

GENERAL

The model 715AN is a 6-digit bi-directional counter, which accepts counts from an optical or shaft encoder, with a quadrature output, and displays the count in degrees.

Four programmable program formats can be selected for the desired reading.

Standard power is 115VAC 50-400Hz, 8 Watts Max, applied to J1 pins 1 and 2.

Remote start, stop, and reset require contact closure or logic common. These signals are in parallel with the front switches. The standard hook up to an encoder is (A & B), (A, B, & Z) or, (A, B, & C), (A,B, Z,& C) with option 11, common, +5 volts, and shield. If rotation causes count to go in the wrong directions, swap A and B inputs.

Z reference is used to reset the display at a certain reference on the rotation of the encoder.

FEATURES

- 4 programmable formats for Degrees or Degrees / Minutes.
- 6 digit .56" red alphanumeric LEDs
- Optional 2 Limit set points
- Programmable decimal points
- Quadrature counting input, programmable for (X1, X2 or X4)
- Z Reference input
- Optional RS-232 or RS-485 interface
- Optional analog out, (0-10 volts) 12 BIT or 16 BIT
- Front panel and remote inputs for start, stop and reset
- 500Khz count rate
- All aluminum case size "A"
- I/O Screw Terminal connector
- 5VDC Excitation Output for encoder

SPECIFICATIONS

Accuracy: +/- 1 count

Temperature Range: -20° to +60° Celsius.

Display: 6 digits, .56", high-efficiency red, alphanumeric 14 segment LED's, 2 limit LED's, and 3 decimal points. The display formats are:

(359.59 Deg. Min:.....Encoder output of 5,400 / 10800 / or 21,600 PPR.

(359.9 Deg).....Encoder output of 900 / 1,800 / or 3,600 PPR.

(359.99 Deg).....Encoder output of 9,000 / 18,000 / or 36,000 PPR.

(359.999 Deg).....Encoder output of 90,000 / 180,000 / or 360,000 PPR.

Inputs:

Quadrature counting: User programmable for X1, X2, or X4.

Z reference: for encoders with Z reference output on each revolution.

Remote start/stop/reset: Requires closure to logic common or TTL logic zero. Input loading 1 LPTTL load.

Logic level inputs: 0 to 5 volt. Maximum count rate is 500 KHz.

Contact closure inputs: Accepts form "C" closure input, or Differential inputs (optional).

Input Power: 115VAC, 50-400 Hz, 8 watts maximum (standard).

230VAC, 50-400 Hz, 8 watts maximum (optional)

5 VDC, @ 500 mA maximum (optional)

9-18 VDC, @ 500 mA maximum (optional)

18-36 VDC, @ 400 mA maximum (optional)

Outputs:

Limits: Two form C output relays, with a maximum current of 0.4A @ 125VAC, or 2A @ 30 VDC (optional)

Analog output: 0-10 VDC scalable, 12 BIT resolution, 4,096 counts 2.45mV (Option 09) or 16 BIT resolution, 65,536 counts 0.15mV (Option 16) and a maximum current of 5mA.

Excitation output: 5VDC on J1 pin 14 &15 can be used to power an encoder.

I/O:

Serial output: RS 232 or 485 with baud rate selectable for 2.4, 4.8, 9.6, 14.4, or 19.2K

Network Address: Selectable from 1 to 255 and 0 = off.

OPTIONS:

- 01 ASCII RS232 serial interface. Baud rates of 2400, 4800, 9600, 14400, 19200.
- 02 ASCII RS485 serial interface. Baud rates of 2400, 4800, 9600, 14400, 19200.
- 05 5 Volt DC Input power @ 500mA maximum
- 09 Analog output. 0-10 Volt DC scaleable, 5 milliamps max
- 10 2 set points with form C relay outputs and LED indication
- 11 Differential input or contact closure
- 12 9-18 Volt DC input
- 16 Analog output. 0-10 Volt DC scaleable, 5 milliamps max, 16 BIT
- 18 Reset switch only
- 19 No front panel switches
- 22 230 Volt AC 50-400Hz 8 watts maximum.
- 24 18-36 Volt DC input power @ 400mA maximum
- 25 Logo and/or nomenclature change. (Special artwork to be supplied.
- 26 No logo
- 28 Blank lens
- 38 "DEGREES" legend
- 39 "DEGREES/MIN" LEGEND
- -XXX= 3 digit # indicates custom software or hardware

SETUP:

The standard factory settings are degrees and setup enabled and X1 quadrature. If other settings are desired, follow the procedure below.

After installing and wiring unit to power and proper inputs (ref: page 9 figure 1) the next step is to program to the desired configuration. Removal the lens to obtain access to the 4 dip switches located between the start and stop switches. The two button head screws holding the lens may be removed with a 1/16" hex key. When switch #1 is off (down) the display will count 1 for 1 with the count input. When switch #1 is on (up), the display counts in degrees. When switch #2 is off (down), the setup parameters are disabled. The limits (option 10) are not disabled. This is useful to lock in the parameters after the lens is replaced. When switch #2 is on (up) the setup parameters are enabled.

Switch #3 & #4 are used to set the Quadrature to X1, X2, and X4 per the setup chart (ref: page 10 figure 2)

SET UP PARAMETER SEQUENCE:

LIMIT 1	OPTION 10 ONLY
LIMIT 1 HI, LO	OPTION 10 ONLY
LIMIT 2	OPTION 10 ONLY
LIMIT 2 HI, LO	OPTION 10 ONLY
DEGREES FORMAT	STANDARD
LEADING ZERO BLANKING	STANDARD
ANALOG OUTPUT ZERO	OPTION 09 ONLY
ANALOG OUTPUT FULL SCALE	OPTION 09 ONLY
BAUD RATE	OPTION 01, 02 ONLY
UNIT ADDRESS	OPTION 01, 02 ONLY
CHARACTER ECHO	OPTION 01, 02 ONLY
SEND LINE FEED	OPTION 01, 02 ONLY
CONTINUOUS READING	OPTION 01, 02 ONLY
READING LEGEND	OPTION 01, 02 ONLY

Note: Options not installed are left out of the sequence. At any time during set up process, you may momentarily press (ENTER/ADVANCE), to advance to the next set up, or (Hold to Exit), to exit setup. When exiting set up the display will stop flashing and revert to the current reading.

Enter Setup mode: To enter setup push (INCREMENT DIGIT) and (NEXT DIGIT) at the same time. The displayed will show Model number 715AN, the revision number, followed by the description of the parameter to be set. If option 10 is installed the parameter (LIMIT 1) for limit 1, will be displayed. If option 10 is not installed the first parameter displayed will be (FORMAT), followed by the range programmed.

Set Limit set points (if option 10 is installed): Limit set points are number limits that trigger relays when exceeded. They may be positive or negative numbers and “LO” or “HI” limits. A “LO” limit set point picks the relay when the count is less than the limit, while a “HI” limit set point picks the relay when the limit is exceeded. The display will read “LIMIT 1” for a second and then the number, which can be changed at this time by pressing the (INCREMENT/DIGIT) switch to change the blinking number, (NEXT DIGIT) to move to the next digit, and (ENTER ADVNACE) to move to the next parameter. The next parameter to be set is limit 1 as a HI or LO limit. The display will read “LIMMOD” for a second and then “HI or LO LIM” which may be toggled to either HI or LOW with the (INCREMENT/DIGIT) switch. Again press (ENTER ADVNACE) to go to the next parameter. The display will read “LIMIT 2” for a second and then the number, which can be changed. Repeat the same steps as used in setting limit 1 and then select either HI or LO. Press (ENTER ADVNACE) to go to the next parameter, or to exit setup press and hold (ENTER ADVNACE).

Set Degrees Format: This displays “FORMAT” for a second and then displays the format that was last selected (example “359.59”). A new format may then be selected by pressing (NEXT DIGIT). When the desired format is displayed press (ENTER/ADVANCE) to go to the next parameter, or to exit setup press and hold (ENTER/ADVANCE).

Set Leading Zero Blanking: This displays “LZBLNK” for a second followed by “ON” or “OFF” and may be toggled on or off with (INCREMENT DIGIT). Press (ENTER/ADVANCE) to go to the next parameter, or to exit setup press and hold (ENTER/ADVANCE).

SET Analog Output Zero (if option 09 is installed): Analog out has two set up parameters, the display number for 0 volts and the display number for span or full scale or 10 volts. 0 is set when the display shows “A0 0” for a second then “888888” with the least significant digit flashing. The flashing digit is changed by pressing (INCREMENT/DIGIT). To go to the next digit press (NEXT DIGIT). After progressing through all 6 digits, the next progression will flash the (-) sign will flash momentarily. The (-) can be toggled on and off by pressing (INCREMENT/DIGIT). Press (ENTER/ADVANCE) to go to the next parameter, or to exit setup press and hold (ENTER/ADVANCE).

SET Analog Output Full Scale (if option 09 is installed): To go to the next parameter, “full scale” press (NEXT DIGIT). Analog FS is displayed as “AO SP” for a second then “000000”, with the least significant digit flashing. The flashing digit is changed by pressing (INCREMENT/DIGIT). To go to the next digit press (NEXT DIGIT). After progressing through all 6 digits, the next progression will flash the (-) sign will flash momentarily. The (-) can be toggled on and off by pressing (INCREMENT/DIGIT).

Note: both the 0 and the full scale can be set to either a negative or positive number. However, the full-scale number must be larger than the 0 number. Again press (ENTER ADVNACE) to go to the next parameter, or to exit setup press and hold (ENTER ADVNACE).

SET SERIAL INTERFACE (Option 01 or 02)

When setting the following parameters use the same procedure of (INCREMENT/DIGIT), (NEXT DIGIT), and (ENTER ADVNACE) as described above.

Set Baud Rate: Baud rate is displayed as “BAUD” for a second, followed by the numeric rate. Toggled through the baud rates and select the one you want

Set Address Selection: Address selection for this particular unit. If this number is “0”, the address is disabled. If this number is from 1 to 255, an “AEXX” code must be sent to enable the serial commands, where XX is the address number assigned. To disable the serial commands an “ADXX”code must be sent.

Set Character Echo: Character echo and displayed as “ECHO” for a second followed by the word “OFF” or “ON” which may be toggled with the “STOP” switch. When echo is on all characters received will be echoed back.

Set Send Line Feed: Send Line Feed, which is displayed as “LF” for a second followed by “OFF” or “ON” which may be toggled with the “STOP” switch. “ON” will select auto line feed after a c.r.

Set Continuous Reading Update: Continuous Reading Update, which is displayed as ”CR” for a second then “000000”. This number may be from –10 to 127. –10 being 10 readings a second, to 127 being 1 reading every 127 seconds.

Set Reading Legend: Reading Legend, which is displayed as “LEGEND” for a second followed by “000000”. This number is from 0 to 10 and prints out the legend per table below.

0=none; 1=’in”; 2=’ft”; 3=’yd”; 4=’mi”; 5=’nm”; 6=’cm”; 7=’m”; 8=’km”; 9=’%”; 10=’deg”

COMMUNICATION

SERIAL COMMAND SET

AD---disable network address
AE---enable network address
EH---turn receive character echo ON/OFF
LF--- turn linefeeds ON/OFF
RD--- read display
S1--- set limit #1
S2--- set limit #2
V1--- verify limit #1
V2--- verify limit #2
ST--- start counter
SP--- stop counter
RS--- reset counter
AZ--- set analog output zero
AS--- set analog output span
MP--- set count multiplier
TM--- output model and firmware revision
CR--- continuous reading –10 to 127
LR--- set legend 0 to 10 per chart above
DP---set decimal point 0-6
ZB--- leading zero blanking ON/OFF

SERIAL COMMUNICATION

The serial data is transmitted as ASCII characters, using the selected baud rate. Each word or character is made up of eight data bits, one stop bit and no parity bit. The format of data transmitted depends on the command, and is expected to be transmitted or received left most character first and terminated with a carriage return (c.r.) when an additional number is required leading zeros or place holders may be omitted. Plus sign is optional but must precede the number. Received numbers will have the decimal point ignored. Transmitted numbers will have a period to conform to the display format. In the command descriptions below the command string will be shown within brackets

{ [] }, the sign if required will be shown as a lower case (s), and the number as upper case (X). Each command will be executed when received and only once except for display data which may be enabled to continuously update until disabled. Most all commands that set some parameter can be sent to the unit without that parameter and it will respond with the current value of that parameter. This allows the user to check those values to be sure the unit received the parameter properly.

Echo: [EHXc.r.]

The echo command is used to turn the echo on and off. When the echo is on the unit will send back out anything that comes in. A zero in place of the X turns the echo off and a one turns the echo on.

Line Feed: [LFXc.r.]

The line feed command is used to turn the line feed on and off. When the line feed is on the unit will follow every message with a line feed character. A zero in place of the X turns the line feed off and a one turns the line feed on.

Address Enable [AEXXXc.r.]

Address enable is a command used with the RS-485 serial interface when several units will be in parallel on the serial buss, or with RS-232 when several units are connected in series, to enable the unit. This command allows the unit specified by the address number XXX to be turned on or enabled, the address must be in the range of 0 to 255. When the address is set to 0 the unit will respond to any command without first receiving the address enable command. When enabled the unit will respond with [HELLOc.r.].

Address Disable [ADXXc.r.], [ADc.r.]

Address disable is a command used with the RS-485 serial interface when several units will be in parallel on the serial buss, or with RS-232 when several units are connected in series, to disable the unit. This command allows the unit specified by the address number XX to be turned off or disabled. The address must be in the range of 1 to 255. If no number is supplied all units on the serial buss will be turned off or disabled. If the unit is disabled by unit address number, the unit will respond with [BYEc.r.].

Read Display: [RDc.r.]

Read display is a command that will return the normal display reading, (display mode when not in Peak, Valley, Span check, etc.). The returned data format will be [sXXX.XXXc.r.] where (s) is the sign if minus, (X) is the number, and (.) is the decimal point if in the display.

Set Limit: [S#XXXXXc.r.]

The set limit command is used to program a limit number for the high or low limit. The first number following the command (#) specifies whether the high limit or low limit is being programmed. A one in this field specifies the high limit, while a two specifies the low limit. The number following this (XXXXX) is the actual limit number to be entered.

Verify Limit: [VXc.r.]

The verify limit command is used to read the current high and low limit settings for the unit. The applied number (X) specifies whether the high or low limit value is to be returned. A one specifies the high limit, while a two specifies the low limit.

Set Analog Output Zero: [AZXXXXXXc.r.]

Set analog output zero is a command that will set the analog output zero. This number is what the display reads when the analog output is at zero volts or 4mA. "AZ" is the command. "X" is the numeric value from 1 to 999999. X may be preceded by a "+" or a "-". The "+" is optional. The unit will respond with [OKc.r.]

Set Analog Output Span: [ASXXXXXXc.r.]

Set analog output span is a command that will set the analog output span. This number is what the display reads when the analog output is at its full-scale point; this can be 10 volts, 5 volts, or 20mA. "AS" is the command. "X" is the numeric value from 1 to 999999. X may be preceded by a "+" or a "-". The "+" is optional. The unit will respond with [OKc.r.].

Test Message: [TMc.r.]

The test message command is a diagnostic aid. When the test message command is received the unit will output all current settings, readings and the model number with software revision.

Continuous Reading: [CFXXXXc.r.]

The continuous reading command allows the auto serial update mode to be selected. It updates all the units with corresponding display data at the selected time interval. The attached number (XXXX) is the numeric value from -1 to 3600. A value of 0 will disable the auto update function. A value of -1 will output data once for every conversion (2.5 times per second). A value of one or greater indicates the number of seconds between updates up to maximum of 3600 seconds between updates.

Set Legend: [LRXXc.r.]

The set legend command allows the selection of a unit indicator, which will be added onto the reading update from the serial output. The number (X) applied to the command indicated which unit from the legend table (on page XX) would be appended to the serial reading.

Pin out

FIGURE 1

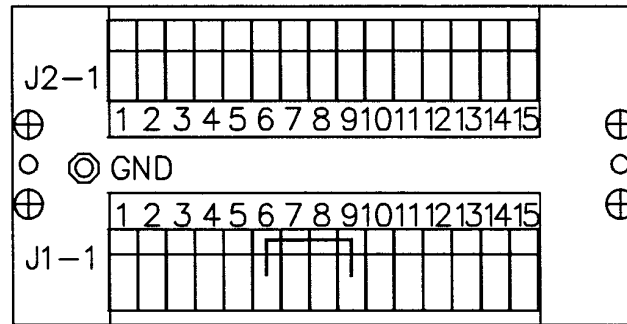

	<u>J1 MAIN BOARD</u>	<u>PIN#</u>	<u>J2 OPTION BOARD</u>	
NOTE 4	115VAC LINE	1	NO	LIMIT 1 RELAY
	115VAC NEUTRAL	2	NC	
	RESET	3	COM	
	STOP	4	NO	LIMIT 2 RELAY
	START	5	NC	
	COMMON	6	COM	
OPTION 01,02	TX232/485	7		
	RX232/485	8		
	Z-INPUT	9		
	A-INPUT	10		
OPTION 11	\bar{A} -INPUT	11		
	B-INPUT	12		
OPTION 11	\bar{B} -INPUT	13	ANALOG OUT	OPTION 09
	+5 VOLTS OUT	14	ANALOG GND	
	COMMON	15		

NOTES

- 1- START, STOP, RESET, TTL LOW or CONTACT CLOSURE TO COMMON.
- 2- TTL INPUTS TO J1-10,12. COM TO PIN 6 OR 15
- 3- FOR Z INPUT REMOVE JUMPER ON PIN 9 AND CONNECT Z INPUT ON PIN 9
- 4- FOR POWER OTHER THAN 115VAC SEE OPTIONS TABLE

SWITCH SETTINGS

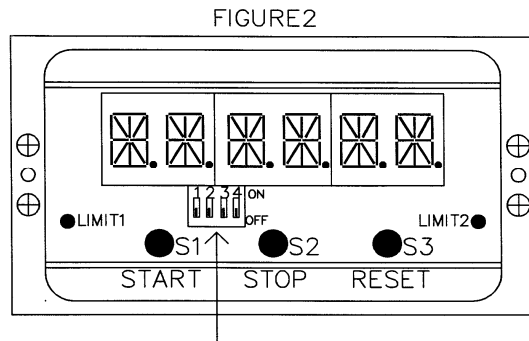

DIP SWITCH SETTINGS

- SWITCH 1 OFF –DIRECT READING
 - SWITCH 1 ON –DEGREE READING\MULTIPLIER ENABLED
 - SWITCH 2 OFF –SETUP DISABLED
 - SWITCH 2 ON –SETUP ENABLED
- | | | |
|-----------------------------------|---|---------------|
| SWITCH 3 OFF
SWITCH 4 OFF | } | QUADRATURE X4 |
| SWITCH 3 ON
SWITCH 4 DONT CARE | } | QUADRATURE X2 |
| SWITCH 3 OFF
SWITCH 4 ON | } | QUADRATURE X1 |

FIGURE 3: Dimensions of case

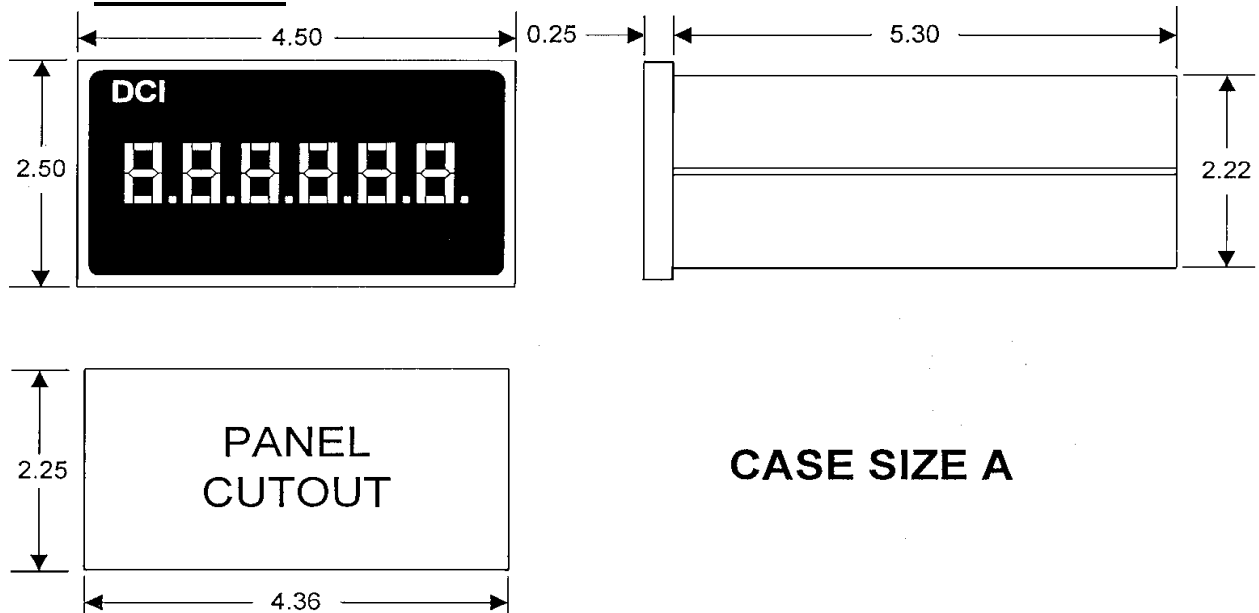

MOUNTING

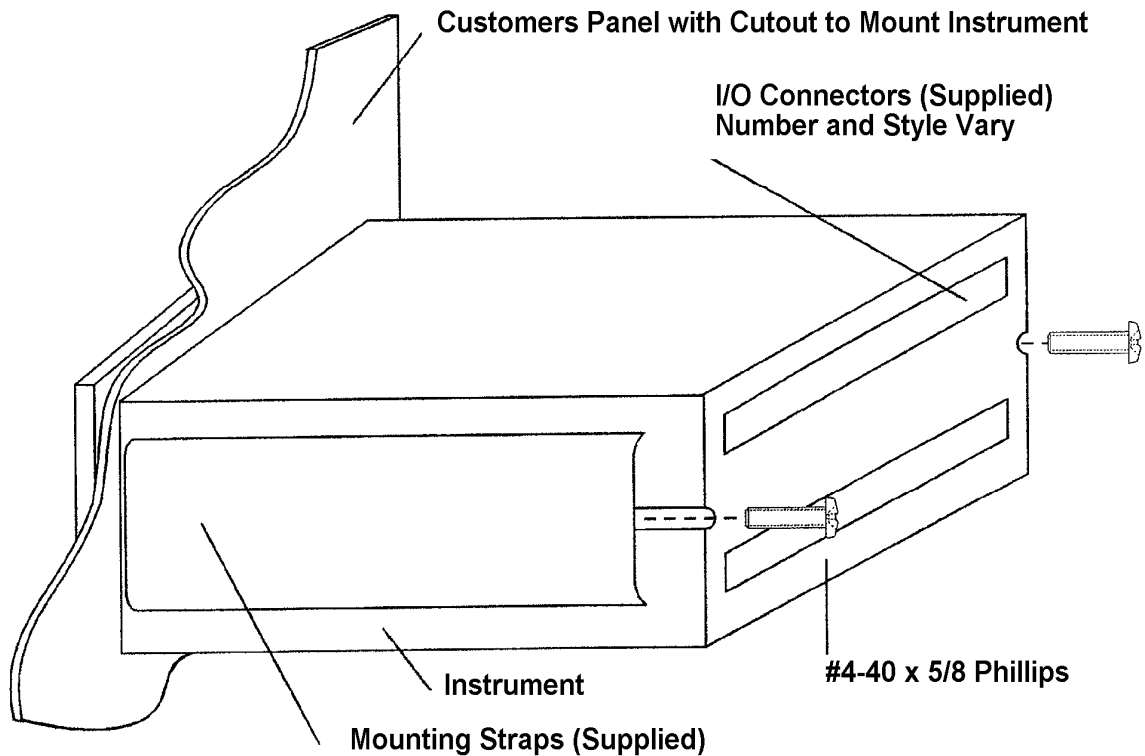

Design Concepts, Inc.
PO Box 2877
707 N. Lindenwood
Olathe, KS 66062
Phone: 913-782-5672
Fax: 913-782-5766

Web: <http://www.designconceptsinc.biz>

WARRANTY

THE FOLLOWING WARRANTY IS IN LIEU OF ALL OTHER WARRANTIES, EXPRESSED, IMPLIED OR STATUTORY, INCLUDING BUT NOT LIMITED TO ANY IMPLIED WARRANTY OF MERCHANTABILITY OR FITNESS FOR A PARTICULAR PURPOSE.

All new products sold by Design Concepts Inc. are warranted against defects in materials and workmanship for one (1) year from the date of the original shipment. During the warranty period, Design Concepts Inc. will repair or, at its option, replace without charge any Design Concepts Inc. product stated above, is limited to the repaired portion and is valid for ninety (90) days from the date of its reshipment. These warranties do not apply if the product has been damaged by accident, misuse, or modification in the absence of authorization from Design Concepts Inc. Design Concepts Inc. will not be responsible or liable for contingent, incidental, secondary or consequential costs of damages.