

**MODEL 714AN  
QUADRATURE  
COUNTER**

**DESIGN CONCEPTS INC**

**707 N. Lindenwood  
Olathe, Kansas 66062**

**PHONE: (913) 782-5672**

**FAX: (913) 782-5766**

**E-MAIL : [info@dcimeters.com](mailto:info@dcimeters.com)**

# TABLE OF CONTENTS

2.....	<b>Features</b>
3.....	<b>Specifications</b>
4.....	<b>Setup</b>
6.....	<b>Serial Commands</b>
11.....	<b>Pin Out and switch settings</b>
13.....	<b>Case size</b>
14.....	<b>Mounting</b>

## GENERAL

The model 714AN is a 6-digit bi-directional counter, which accepts counts from an optical or shaft encoder, with a quadrature output, and displays the count. A programmable four digit fractional multiplier scales the meter to the desired reading. Standard power is 115VAC 50-400Hz, 8 Watts Max, applied to J1 pins 1 and 2. Remote start, stop, and reset require contact closure or logic common. These signals are in parallel with the front switches. The standard hook up to an encoder is (A & B), (A, B, & Z) or, (A, B, & C), (A,B, Z,& C) with option 11, common, +5 volts, and shield. If rotation causes count to go in the wrong directions, swap A and B inputs. Z reference is used to reset the display at a certain reference on the rotation of the encoder.

## FEATURES

- 6 digit .56" red alphanumeric LEDs
- Optional 2 Limit set points
- Programmable decimal points
- Quadrature counting input, programmable for (X1, X2 or X4)
- Optional RS-232 or RS-485 interface
- Optional 10BASE-T/100BASE-TX Ethernet Interface
- Optional analog out, (0-10 volts) 12 BIT or 16 BIT
- Front panel and remote inputs for start, stop and reset
- Programmable fractional input multiplier (0 to 5.9999)
- 500Khz count rate
- All aluminum case size "A"
- I/O Screw Terminal connector
- 5VDC Excitation Output for encoder
- Through zero counting and indication.

## **SPECIFICATIONS:**

**Accuracy:** +/- 1 count

**Temperature Range:** -20° to +60° Celsius

**Display:** 6 digits.56" tall, 14 segment red LED with decimals and 2 limit LED's.  
The display range is from -199999 to +999999.

### **Inputs:**

**Quadrature counting:** User programmable for X1, X2, or X4.

**Z reference:** for encoders with Z reference output on each revolution.

**Remote start/stop/reset:** Requires closure to logic common or TTL logic zero. Input loading 1 LPTTL load.

**Logic level inputs:** 0 to 5 volt. Maximum count rate is 500Khz.

**Contact closure inputs:** Accepts form "C" closure input, or Differential inputs (optional).

### **Input Power:**

115VAC 50-400hz, 8 watts max (standard).

230VAC, 50-400hz, 8 watts max

5 VDC, @ 500 mA max

9-18 VDC, @ 500 mA max

18-36 VDC, @ 400 mA max

### **Outputs:**

**Limits:** Two form C output relays, with a maximum current of 0.4A @ 125VAC, or 2A @ 30 VDC (optional)

**Analog output:** 0-10 VDC scalable, 12 BIT resolution, 4,096 counts 2.45mV (Option 09), or 16 BIT resolution, 65,536 counts 0.15mV (Option 16), and a maximum current of 5mA

**Excitation output:** 5VDC on J1 pin 14 &15 can be used to power an encoder.

### **I/O:**

**Serial output:** RS 232 or 485 with baud rate selectable for 2.4, 4.8, 9.6, 14.4, or 19.2K

**Network Address:** Selectable from 1 to 255 and 0 = off.

**Ethernet Output:** 10BASE-T/100BASE-TX

### **OPTIONS:**

01 ASCII RS232 serial interface. Baud rates of 2400, 4800, 9600, 14400, 19200.

02 ASCII RS485 serial interface. Baud rates of 2400, 4800, 9600, 14400, 19200.

03 Ethernet interface.

05 5 Volt DC Input power @ 500mA maximum

09 Analog output. 0-10 Volt DC scaleable, 5 milliamps max, 12 BIT

10 2 set points with form C relay outputs and LED indication

11 Differential input or contact closure

12 9-18 Volt DC input

16 Analog output. 0-10 Volt DC scaleable, 5 milliamps max, 16 BIT

22 230 Volt AC, 50-400Hz, 8 watts maximum.

24 18-36 Volt DC input power @ 400mA maximum

25 Logo and/or nomenclature change, (Special artwork to be supplied).

26 No logo

28 Blank lens

36 "COUNTER" legend

37 "RPM" legend

38 "DEGREES" legend-XXX= 3 digit # indicates custom software or hardware

## SETUP:

The standard factory settings are multiplier and setup enabled and X1 quadrature. If other settings are desired, follow the procedure below.

After installing and wiring unit to power and proper inputs (ref: page 9 figure 1) the next step is to program to the desired configuration. Removal the lens to obtain access to the 4 dip switches located between the start and stop switches. The two button head screws holding the lens may be removed with a 1/16" hex key. When switch #1 is off (down) the display will count 1 for 1 with the count input. When switch #1 is on (up), the fractional multiplier is enabled. When switch #2 is off (down), the setup parameters are disabled. The limits (option 10) are not disabled. This is useful to lock in the parameters after the lens is replaced. When switch #2 is on (up) the setup parameters are enabled.

Switch #3 & #4 are used to set the Quadrature to X1, X2, and X4 per the setup chart (ref: page 10 figure 2)

### SET UP PARAMETER SEQUENCE:

LIMIT 1	OPTION 10 ONLY
LIMIT 1 HI, LO	OPTION 10 ONLY
LIMIT 2	OPTION 10 ONLY
LIMIT 2 HI, LO	OPTION 10 ONLY
DISPLAY MULTIPLIER	
DECIMAL POINT	
LEADING ZERO BLANKING	
ANALOG OUTPUT ZERO	OPTION 09, 16 ONLY
ANALOG OUTPUT FULL SCALE	OPTION 09, 16 ONLY
BAUD RATE	OPTION 01, 02 ONLY
UNIT ADDRESS	OPTION 01, 02 ONLY
CHARACTER ECHO	OPTION 01, 02 ONLY
SEND LINE FEED	OPTION 01, 02 ONLY
CONTINUOUS READING	OPTION 01, 02 ONLY
READING LEGEND	OPTION 01, 02 ONLY

**Note:** Options not installed are left out of the sequence. At any time during set up process, you may momentarily press (ENTER/ADVANCE), to advance to the next set up, or (Hold to Exit), to exit setup. When exiting set up the display will stop flashing and revert to the current reading.

When setting any number to a negative value, the maximum number us -199999.

**Enter Setup mode:** To enter setup push (INCREMENT DIGIT) and (NEXT DIGIT) at the same time. The displayed will show Model number 714AN, the revision number, followed by the description of the parameter to be set. If option 10 is installed the parameter (LIMIT 1) for limit 1, will be displayed. If option 10 is not installed the first parameter displayed will be (MULT) for multiplier, followed by the multiplier number with the least significant digit flashing.

**Set Limit set points (if option 10 is installed):** Limit set points are number limits that trigger relays when exceeded. They may be positive or negative numbers and “LO” or “HI” limits. A “LO” limit set point picks the relay when the count is less than the limit, while a “HI” limit set point picks the relay when the limit is exceeded. The display will read “LIMIT 1” for a second and then the number, which can be changed at this time by pressing the (INCREMENT/DIGIT) switch to change the blinking number, (NEXT DIGIT) to move to the next digit, and (ENTER ADVNACE) to move to the next parameter. The next parameter to be set is limit 1 as a HI or LO limit. The display will read “LIMMOD” for a second and then “HI or LO LIM” which may be toggled to either HI or LOW with the (INCREMENT/DIGIT) switch. Again press (ENTER ADVNACE) to go to the next parameter. The display will read “LIMIT 2” for a second and then the number, which can be changed. Repeat the same steps as used in setting limit 1 and then select either HI or LO. Press (ENTER ADVNACE) to go to the next parameter, or to exit setup press and hold (ENTER ADVNACE).

**Set Multiplier:** The fractional multiplier for the count input, when set to “.0000” will display the count input. When set to any other number, then that is the fractional number that the actual count input would be multiplied by. (Example: If set to .125 a count of 1000 would display 125). A flashing digit can be changed by pressing, (INCREMENT DIGIT). To go to the next digit press (NEXT DIGIT). To go to the next parameter, press (ENTER/ADVANCE), or to exit setup press and hold (ENTER/ADVANCE).

**Set Decimal:** This displays “DP” for a second and then displays “888888”. The decimal point may then be selected by pressing (INCREMENT DIGIT), to move 1 position to the left, or (NEXT DIGIT) to move 1 position to the right. Press (ENTER/ADVANCE) to go to the next parameter, or to exit setup press and hold (ENTER/ADVANCE).

**Set Leading Zero Blanking:** This displays “LZBLNK” for a second followed by “ON” or “OFF” and may be toggled on or off with (INCREMENT DIGIT). Press (ENTER/ADVANCE) to go to the next parameter, or to exit setup press and hold (ENTER/ADVANCE).

**SET Analog Output Zero (if option 09 or 16 is installed):** Analog out has two set up parameters, the display number for 0 volts and the display number for span or full scale or 10 volts. 0 is set when the display shows “A0 0” for a second then “888888” with the least significant digit flashing. The flashing digit is changed by pressing (INCREMENT/DIGIT). To go to the next digit press (NEXT DIGIT). After progressing through all 6 digits, the next progression will flash the (-) sign will flash momentarily. The (-) can be toggled on and off by pressing (INCREMENT/DIGIT). Press (ENTER/ADVANCE) to go to the next parameter, or to exit setup press and hold (ENTER/ADVANCE).

**SET Analog Output Full Scale (if option 09 or 16 is installed):** To go to the next parameter, “full scale” press (NEXT DIGIT). Analog FS is displayed as “AO SP” for a second then “000000”, with the least significant digit flashing. The flashing digit is changed by pressing (INCREMENT/DIGIT). To go to the next digit press (NEXT DIGIT). After progressing through all 6 digits, the next progression will flash the (-) sign will flash momentarily. The (-) can be toggled on and off by pressing (INCREMENT/DIGIT).

**Note:** both the 0 and the full scale can be set to either a negative or positive number. However, the full-scale number must be larger than the 0 number. Again press (ENTER ADVNACE) to go to the next parameter, or to exit setup press and hold (ENTER ADVNACE).

## **SET SERIAL INTERFACE (Option 01 or 02)**

When setting the following parameters use the same procedure of (INCREMENT/DIGIT), (NEXT DIGIT), and (ENTER ADVNACE) as described above.

**Set Baud Rate:** Baud rate is displayed as “BAUD” for a second, followed by the numeric rate. Toggled through the baud rates and select the one you want

**Set Address Selection:** Address selection for this particular unit. If this number is “0”, the address is disabled. If this number is from 1 to 255, a “AEXX” code must be sent to enable the serial commands, where XX is the address number assigned. To disable the serial commands an “ADXX” code must be sent.

**Set Character Echo:** Character echo and displayed as “ECHO” for a second followed by the word “OFF” or “ON” which may be toggled with the “STOP” switch. When echo is on all characters received will be echoed back.

**Set Send Line Feed:** Send Line Feed, which is displayed as “LF” for a second followed by “OFF” or “ON” which may be toggled with the “STOP” switch. “ON” will select auto line feed after a c.r.

**Set Continuous Reading Update:** Continuous Reading Update, which is displayed as “CR” for a second then “000000”. This number may be from -10 to 127. -10 being 10 readings a second, to 127 being 1 reading every 127 seconds.

**Set Reading Legend:** Reading Legend, which is displayed as “LEGEND” for a second followed by “000000”. This number is from 0 to 15 and prints out the legend per table below.

0=none; 1=“in”; 2=“ft”; 3=“yd”; 4=“mi”; 5=“nm”; 6=“cm”; 7=“m”; 8=“km”; 9=“%”; 10=“deg”; 11=dpm; 12=rpm; 13=ipm; 14=degrees/min; 15=degrees

## COMMUNICATION (SERIAL COMMAND SET):

AD---disable network address	SP--- stop counter
AE---enable network address	RS--- reset counter
EH---turn receive character echo ON/OFF	AZ--- set analog output zero
LF--- turn linefeeds ON/OFF	AS--- set analog output span
RD--- read display	MP--- set count multiplier
S1--- set limit #1	TM--- output model and firmware revision
S2--- set limit #2	CR--- continuous reading -10 to 127
V1--- verify limit #1	LR--- set legend 0 to 10 per chart above
V2--- verify limit #2	DP---set decimal point 0-6
ST--- start counter	ZB---- leading zero blanking ON/OFF

## SERIAL COMMUNICATION

The serial data is transmitted as ASCII characters, using the selected baud rate. Each word or character is made up of eight data bits, one stop bit and no parity bit. The format of data transmitted depends on the command, and is expected to be transmitted or received left most character first and terminated with a carriage return (c.r.) when an additional number is required leading zeros or place holders may be omitted. Plus sign is optional but must precede the number. Received numbers will have the decimal point ignored. Transmitted numbers will have a period to conform to the display format. In the command descriptions below the command string will be shown within brackets

{[ ]}, the sign if required will be shown as a lower case (s), and the number as upper case (X). Each command will be executed when received and only once except for display data which may be enabled to continuously update until disabled. Most all commands that set some parameter can be sent to the unit without that parameter and it will respond with the current value of that parameter. This allows the user to check those values to be sure the unit received the parameter properly.

### **Echo: [EHXc.r.]**

The echo command is used to turn the echo on and off. When the echo is on the unit will send back out anything that comes in. A zero in place of the X turns the echo off and a one turns the echo on.

### **Line Feed: [LFXc.r.]**

The line feed command is used to turn the line feed on and off. When the line feed is on the unit will follow every message with a line feed character. A zero in place of the X turns the line feed off and a one turns the line feed on.

### **Address Enable [AEXXXc.r.]**

Address enable is a command used with the RS-485 serial interface when several units will be in parallel on the serial buss, or with RS-232 when several units are connected in series, to enable the unit. This command allows the unit specified by the address number XXX to be turned on or enabled, the address must be in the range of 0 to 255.

When the address is set to 0 the unit will respond to any command without first receiving the address enable command. When enabled the unit will respond with [HELLOc.r.].

**Address Disable [ADXXXc.r.], [ADc.r.]**

Address disable is a command used with the RS-485 serial interface when several units will be in parallel on the serial buss, or with RS-232 when several units are connected in series, to disable the unit. This command allows the unit specified by the address number XX to be turned off or disabled. The address must be in the range of 1 to 255. If no number is supplied all units on the serial buss will be turned off or disabled. If the unit is disabled by unit address number, the unit will respond with [BYEc.r.].

**Read Display: [RDc.r.]**

Read display is a command that will return the normal display reading, (display mode when not in Peak, Valley, Span check, etc.). The returned data format will be [sXXX.XXXc.r.] where (s) is the sign if minus, (X) is the number, and (.) is the decimal point if in the display.

**Set Limit: [S#XXXXXXc.r.]**

The set limit command is used to program a limit number for the high or low limit. The first number following the command (#) specifies whether the high limit or low limit is being programmed. A one in this field specifies the high limit, while a two specifies the low limit. The number following this (XXXXXX) is the actual limit number to be entered.

**Verify Limit: [VXc.r.]**

The verify limit command is used to read the current high and low limit settings for the unit. The applied number (X) specifies whether the high or low limit value is to be returned. A one specifies the high limit, while a two specifies the low limit.

**Set Analog Output Zero: [AZXXXXXXXXc.r.]**

Set analog output zero is a command that will set the analog output zero. This number is what the display reads when the analog output is at zero volts or 4mA. "AZ" is the command. "X" is the numeric value from 1 to 999999. X may be preceded by a "+" or a "-". The "+" is optional. The unit will respond with [OKc.r.]

**Set Analog Output Span: [ASXXXXXXXXc.r.]**

Set analog output span is a command that will set the analog output span. This number is what the display reads when the analog output is at its full-scale point; this can be 10 volts, 5 volts, or 20mA. "AS" is the command. "X" is the numeric value from 1 to 999999. X may be preceded by a "+" or a "-". The "+" is optional. The unit will respond with [OKc.r.].

**Test Message: [TMc.r.]**

The test message command is a diagnostic aid. When the test message command is received the unit will output all current settings, readings and the model number with software revision.

**Continuous Reading: [CFXXXXc.r.]**

The continuous reading command allows the auto serial update mode to be selected. It updates all the units with corresponding display data at the selected time interval. The attached number (XXXX) is the numeric value from -1 to 3600. A value of 0 will disable the auto update function. A value of -1 will output data once for every conversion (2.5 times per second). A value of one or greater indicates the number of seconds between updates up to maximum of 3600 seconds between updates.

**Set Legend: [LRXXc.r.]**

The set legend command allows the selection of a unit indicator, which will be added onto the reading update from the serial output. The number (X) applied to the command indicated which unit from the legend table (on page XX) would be appended to the serial reading.

## Ethernet Communication

Design Concepts is using the Lantronix XPort module ([www.lantronix.com](http://www.lantronix.com)) for the Ethernet option. This device takes the serial data inside the unit which is normally output over the RS-232 or RS-485 interfaces and redirects it to the Ethernet port. This allows all but two commands outlined above in the Serial Communication section to also be used with the Ethernet Interface. Those two commands are Address Enable and Address Disable, these commands are simply not needed with the Ethernet interface due to the inherent addressing built into the Ethernet port. There are no setup options available from the front panel for the Ethernet option.

**Configuring the Ethernet Module:**

In order to communicate with the 714AN over the Ethernet, you must first discover or assign it an IP address. Lantronix provides a setup software called DeviceInstaller that will scan the local network for XPort devices and then allows you to setup the IP address as well as the serial settings. The serial setup of the XPort must match the serial setup of the 714AN. The default serial setup is 9600, N, 8,1.

The IP address can also be set using ARP as in the following instructions.

1. Open a windows command prompt (Start, Run, enter command or CMD depending on your operating system)
2. From the dos command prompt enter the IP address and MAC address as shown below:  
C:\ARP -S 192.168.xxx.xxx 00-20-4A-xx-xx-xx (The IP address is of your choosing. The MAC address can be found on a sticker located on the back of the 714AN)
3. Hit return
4. At the next command prompt telnet to the same IP address using port 1  
e.g. C:\Telnet 192.168.xxx.xxx 1 (This command tells the 714AN to temporarily take the IP address shown.)
5. Hit return. (message 'failed to connect' should appear within 2 to 3 seconds)
6. At the next command prompt telnet to the same IP address using port 9999  
C:\Telnet 192.168.xxx.xxx 9999 (This command takes you into the

- configuration of the XPort module in order to set certain parameters.)
7. Hit return. You will be prompted to "Press Enter to go into Setup Mode"
  8. Hit return again as soon as you see the prompt to access the configuration choices. The prompt will time out after ~ 3 seconds.
  9. Select 0 for server configuration.
  10. Manually enter the IP Address. This permanently assigns the IP address,
  11. Manually enter the gateway address (optional)
  12. Manually enter the host bits for the subnet mask (refer to XPort™ User Manual, section 4, Table 4.1 – Standard IP network Netmasks)
  13. Select 9 to save and exit
  14. The IP address is now set. Basic communications can now be established with the 714AN for testing purposes.
  15. At the next command prompt telnet to the same IP address using port 10001  
C:\Telnet 192.168.xxx.xxx 10001
  16. Hit return. Anything entered from the keyboard will now be sent directly to the 714AN. Typing RD will return the display reading. Typing TM will return the model number and current software revision number.

## Pin out

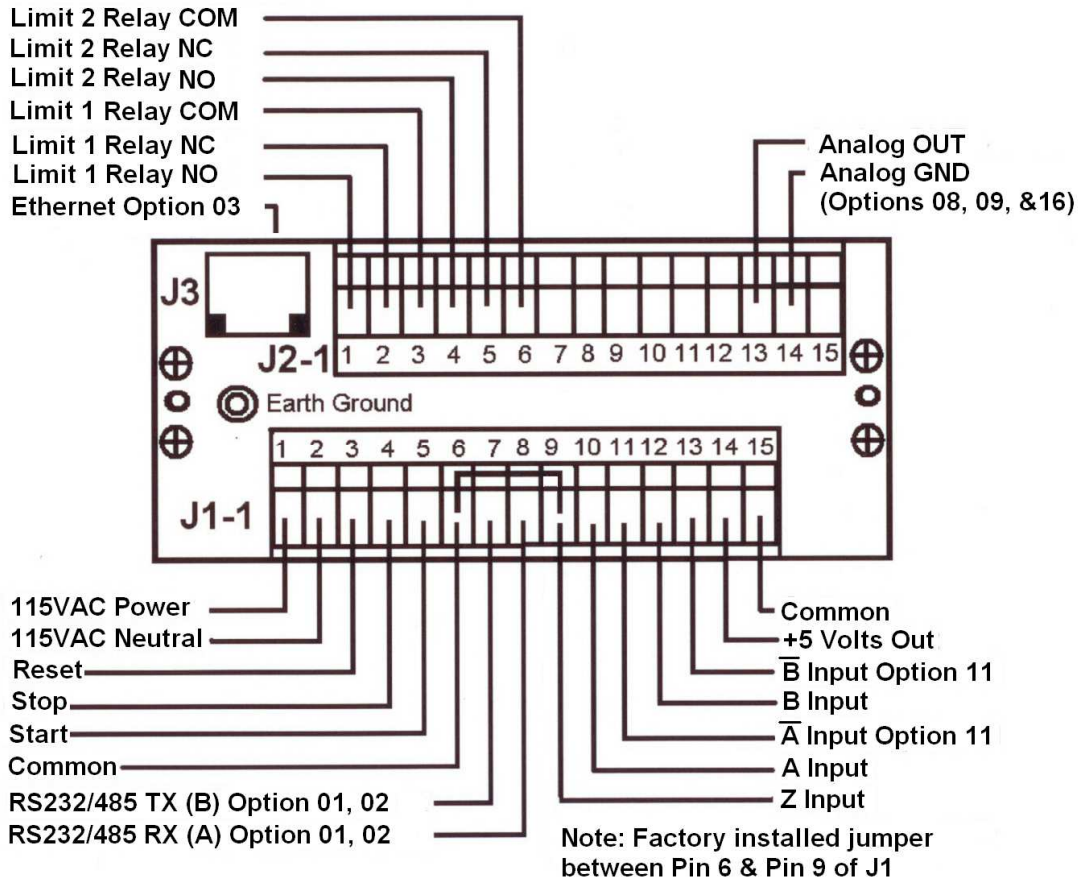

INPUT POWER CONNECTIONS				
Input Power	Pin # / Input	Pin # / Input	Connector Number	Option Number
5VDC	15 = Common	14 = + Power	J1	05
9 to 18VDC	1 = Common	2 = + Power	J1	12
18 to 36VDC	1 = Common	2 = + Power	J1	24
230 VAC	1 = Line	2 = Neutral	J1	22
115 VAC	1 = Line	2 = Neutral	J1	Standard

# SWITCH SETTINGS

FIGURE 2

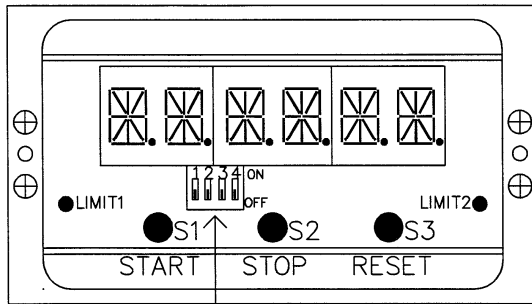

DIP SWITCH SETTINGS

SWITCH 1 OFF – DIRECT READING

SWITCH 1 ON – MULTIPLIER ENABLED

SWITCH 2 OFF – SETUP DISABLED

SWITCH 2 ON – SETUP ENABLED

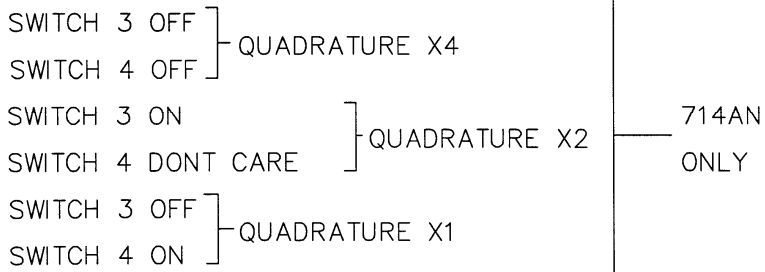

## FIGURE 3 Dimensions of case

### CASE SIZE A

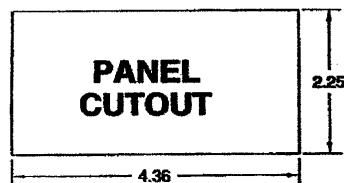
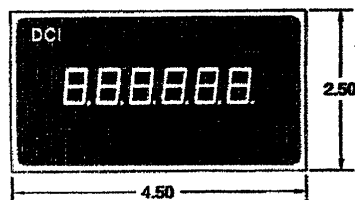
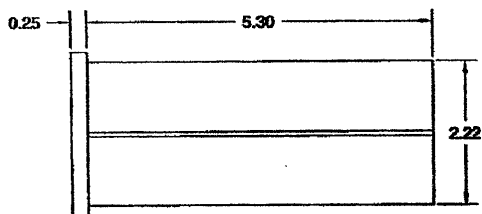

# MOUNTING

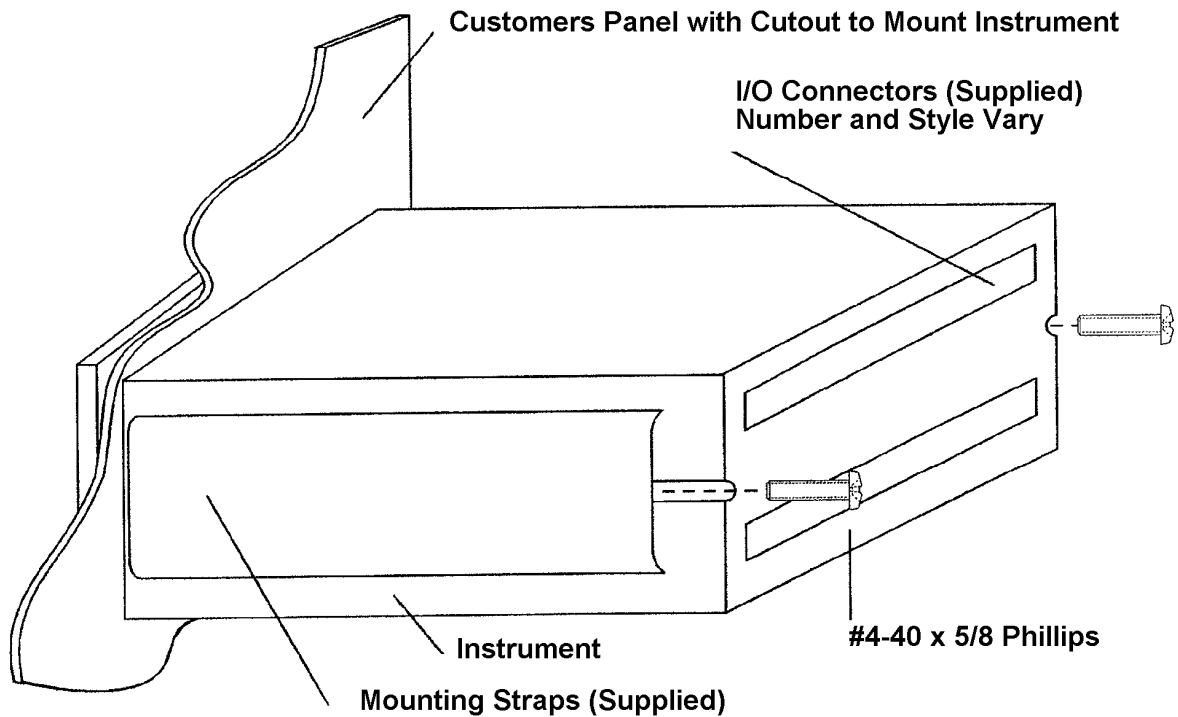

**Design Concepts, Inc.**  
**PO Box 2877**  
**707 N. Lindenwood**  
**Olathe, KS 66062**  
**Phone: 913-782-5672**  
**Fax: 913-782-5766**  
Web: <http://www.dcmeters.com>

## WARRANTY

THE FOLLOWING WARRANTY IS IN LIEU OF ALL OTHER WARRANTIES, EXPRESSED, IMPLIED OR STATUTORY, INCLUDING BUT NOT LIMITED TO ANY IMPLIED WARRANTY OF MERCHANTABILITY OR FITNESS FOR A PARTICULAR PURPOSE.

All new products sold by Design Concepts Inc. are warranted against defects in materials and workmanship for one (1) year from the date of the original shipment. During the warranty period, Design Concepts Inc. will repair or, at its option, replace without charge any Design Concepts Inc. product sated above, is limited to the repaired portion and is valid for ninety (90) days from the date of its reshipment. These warranties do not apply if the product has been damaged by accident, misuse, or modification in the absence of authorization form Design Concepts Inc. Design Concepts Inc. will not be responsible or liable for contingent, incidental, secondary or consequential costs of damages.